



1. In awarding Liquor Expresses (LE) to proponents the NLC
 - a. Will generally not permit a LE to be established in motels, hotels, restaurants, licensed establishments; and
 - b. Will generally award LEs to persons with already existing businesses.
2. LEs will be responsible for providing, at their expense, all interior design, renovation and finish for the LE operations, in accordance with NLC standards. All operating expenses and costs will be the responsibility of the LE. Details of financial and spacing requirements are attached as Schedule A.
3. The LE will be required to carry an appropriate brand selection, as determined by the NLC, and will be required to have adequate retail and warehouse space, in the opinion of the NLC, to accommodate this selection.
4. The LE will purchase the products from the NLC on a payment basis acceptable to the NLC. The purchase price will be the regular retail price of the goods, less the LE commission.
5. The commission is as follows:
 - a. 10.3% on sales up to \$250,000; and
 - b. 5.15% on sales exceeding \$250,000 in any fiscal year of the NLC.
6. The LE will, if required by the NLC, pay the purchase price on delivery of the goods.
7. The LE will, if required by NLC, provide security acceptable to the NLC for the payment of the purchase price.
8. The NLC will deliver the product to the LE at schedules established by the NLC, and the NLC will bear the freight cost.
9. The LE will be required to report monthly/quarterly to the NLC, and the NLC will supply the necessary reporting forms and operating instructions.
10. The LE will operate as a self-service outlet.
11. The applicant shall complete fully the attached application.

12. The NLC will perform certain background checks on prospective applicants, including, but not limited to the following:
- a. Credit checks;
 - b. Financial information review from the applicant's financial institution or institutions;
 - c. Certificates of Conduct or equivalent from police authorities;
 - d. Where necessary, corporate searches respecting the name, existence and directors of the corporation;
 - e. Searches of the Personal Property Securities Registry;
 - f. Searches of the Judgment Enforcement Registry; and
 - g. Searches, where necessary, of other registries and government authorities that record liens or potential liens against.

Where necessary, the applicant will be required to sign a consent or authorization necessary for such authorities to release information to the NLC.

13. The applicant, if a corporation, will be required to:
- h. provide with the application an Officer's Certificate in form annexed hereto as Schedule B; and
 - i. provide with the application a copy of its last 5 years financial statements.
14. The successful applicant will be required to sign a Liquor Express Agreement and a Security Agreement in form acceptable to the NLC.
15. Further details will be made available by the NLC's authorized representative during the site visit and inspection.

NOTWITHSTANDING ANYTHING CONTAINED HEREIN, THE NLC SHALL NOT BE REQUIRED, AS A RESULT OF THE ADVERTISING FOR A LIQUOR EXPRESS, TO AWARD A LIQUOR EXPRESS OUTLET TO ANY APPLICANT, AND RESERVES THE RIGHT TO CANCEL THE REQUEST FOR PROPOSALS AND/OR READVERTISE AND/OR SELECT ANY SUITABLE PERSON OR CORPORATION, WHETHER AN APPLICANT OR NOT, FOR THE OPERATION OF THE LIQUOR EXPRESS.

Please forward application to:

Liquor Express Sales Specialist/Business Development
Newfoundland and Labrador Liquor Corporation
P.O. Box 8750, Station A
St. John's, NL
A1B 3V1

Fax: (709) 724-2250



Please read the following carefully:

There are four sections to this application – Section A, B, C and D. Failure to complete any or all sections may result in rejection of the application.

Upon receipt, the information contained is deemed CONFIDENTIAL.

The word “applicant” means the corporation or the persons or the person who will be appointed Operator and on whose behalf this application is made.

If the applicant is a corporation, the president must complete the application; in the case of a partnership, each partner must sign the application; in the case of a sole proprietorship, the owner must sign the application.

If additional copies of Sections B & C are required, the applicant should photocopy that section for use in completion of the application.

SECTION A - BUSINESS HISTORY REPORT

Please Print

1. Area Applied For As Advertised

--

2. Business Name of Establishment

--

3. Location of Establishment

--

4. Mailing Address

Postal Code

<hr/> <hr/>	
-------------	--

5. Business Establishment

Telephone Number

Fax Number

E-Mail Address

--	--	--

6. Telephone Number Where Applicant
Can Be Reached During Business Hours

--

7. Names of Applicants (Sole owner or partners or officers of a corporation)

Name	Address

8. Is Applicant Sole Owner? _____ Yes _____ No

(a) If a partnership, list the percentage of ownership of each partner:

Name	Percentage

(b) If a corporation, give:

Date of Incorporation:
Public or Private Company:
Provincial or Federal Charter:
Number of Common Shares Authorized:
Number of Common Shares Outstanding:

List Shareholders:

Name	Address	No. of Common Shares Owned	No. of Preferred Shares Owned

9. Do any Shareholders have any direct or indirect financial interest in any enterprise which manufactures or sells alcoholic beverages, including a Brewers' Agent Licence?

_____ Yes _____ No

If Yes, give details, including Brewers' Agent Licence No.

10. State whether applicant will occupy building as owner or tenant: _____

If premises are leased, enclose a copy of the lease.

11. State particulars of any mortgage or charge to which the premises or chattels are to be subject, including the name of the financial institution holding the mortgage or charge:

12. The premises are built of _____ and the age of the premises is _____ years.
(type of construction)

13. Briefly describe the types of business now carried on at the address given:

14. Current Hours of Opening: _____

15. In conjunction with what type of business will the Liquor Express store be operated?

16. Name of person who will manage the Liquor Express store _____

17. Name, Address, and Date of Birth of persons who will be employed in the establishment, other than the Manager:

Name	Address
------	---------

Date of Birth	Place of Birth
---------------	----------------

Name	Address
------	---------

Date of Birth	Place of Birth
---------------	----------------

18. Has any person named in Question 17 ever been convicted of a criminal offence or breach of the Liquor Control Act?

_____ Yes _____ No

If Yes, give details:

19. How long has the applicant carried on business at the address given?

20. How long has the applicant carried on business described in Question 15?

21. Enclose copies of financial statements for the past five years; if not available, give reason:

22. Give three business references. Have your references complete the form included in Appendix A and submit each with your application.

Please note – the business references need to be associated with the current business listed in this Liquor Express application and should be able to comment on the payment/credit status of your account(s); ie Grocery Supplier, Beer Vendors, Dairy Vendors, Gas Supplier, Lottery, Tobacco, etc.

Name _____

Address _____

Telephone No: _____ Fax No: _____

Name _____

Address _____

Telephone No: _____ Fax No: _____

Name _____

Address _____

Telephone No: _____ Fax No: _____

Date

Signature of Applicant

Date

Signature of Applicant

Date

Signature of Applicant



SECTION B - PERSONAL HISTORY REPORT

Please Print

This form is to be completed by individual applicants, partners, or officers of a corporation applying for the Liquor Express. If additional forms are required, please photocopy this section. Upon completion, these reports is to be attached and will form part of the application.

Name in Full:	Surname: _____ Given Names: _____
Date of Birth:	
Place of Birth:	
Home Address:	
Home Telephone #:	
Fax #:	

1. Place of Residence During the Past 10 Years:

Place	Date

2. Details of Employment for the past 10 years:

Dates	Occupation	Location	Employer

3. Have you or any of your family ever been employed by the Newfoundland Labrador Liquor Corporation?

_____ Yes _____ No

If Yes, give details:

4. Do you have any past or present, direct or indirect, financial interest in any enterprise which manufactures or sells alcoholic beverages, including a Brewers' Agent Licence?

_____ Yes _____ No

If Yes, give details, including Brewers' Agent Licence No.

5. Are there any civil court judgements, executions, liens, or similar obligations outstanding against you for any reason anywhere?

_____ Yes _____ No

If Yes, give details:

6. Have you even been convicted of a criminal offence under the Criminal Code of Canada, or any offence anywhere involving drugs or gambling or any offence against any law of any province in Canada involving spirits, wine or beer?

_____ Yes _____ No

If Yes, give details:

7. Have you, in your personal capacity or in your association with any group, company, or corporation, ever been the subject of bankruptcy proceedings?

_____ Yes _____ No

If Yes, give details:

Date

Signature of Applicant



SECTION D - FINANCIAL INFORMATION

Required information with the application is the most recent **five years financial statements** prepared and/or audited or reviewed by a professional accountant.

These financial statements are to be prepared in accordance with Canadian Generally Accepted Accounting Principles and must include a statement of earnings, balance sheet, and statement of cash flows with accompanying notes.

If the operation that will contain the Liquor Express is a division of a larger entity (Corporate or otherwise) the last five years financial statements for the entity containing the operation are required, in addition to providing, at a minimum, the last five years statements of net earnings specific to the operation at the proposed Liquor Express site. You should also provide a letter from the professional accountant who prepared and/or audited or reviewed the entity financial statements indicating the financial information specific to the operation at the proposed site forms part of the entity level statements.

If any of this information cannot be provided, please explain. The information not provided could impact the rating of your application.

This information will be held in strictest confidence.



Please complete the attached form for tax clearance purposes and fax to the St. John's Taxation Centre at 709-754-5928.

The requested letter will indicate whether your business is in good standing with Canada Revenue Agency with respect to HST/GST, Payroll Taxes and Corporate Taxes.

Once you receive a reply from Canada Revenue Agency, please forward the letter directly the NLC for consideration with your application. Please fax the letter to 709-724-2250 (Attention: Liquor Express Sales Specialist/Business Development)

Please note that this takes approximately 4 weeks to be processed, so please complete and fax as soon as possible.

Canada Revenue Agency
St. John's Taxation Centre
Fax Number: 709-754-5928

Please provide an account status comfort letter indicating the status and standing of the following business with respect to HST/GST, payroll tax, and corporate tax accounts.

Business Name: _____

Business Number: **BN** _____

Business Address: _____

Business Telephone Number: _____

Name of Authorized Individual: _____



SCHEDULE A

Liquor Express - Category "D" Requirements

Estimated Annual Sales \$249,999 or less

Estimated Opening Inventory Investment: \$50,000

Minimum Linear Footage:

Perimeter Spirit Shelving: 120 ft – 140 ft

Wine Island Fixture: 32 ft - 48 ft

Ready to Drink Cold Space: 20 ft

Walk-In Beer Room 80 sqft



SCHEDULE B

OFFICER'S CERTIFICATE

TO: NEWFOUNDLAND LABRADOR LIQUOR CORPORATION
(the "NLC")

RE: _____ (Company Name) (the "Company")

I, _____ [name] being _____ [title] of the Company, after having made necessary investigations of corporate records and inquiries of other officers, directors, and senior personnel of the Company, hereby do solemnly declare as follows:

1. The Company was incorporated under the provisions of the [Corporations Act or equivalent in the jurisdiction] (the "Act") on the _____ day of _____, _____. A true and complete copy of the Certificate of Incorporation of the Company (the "Articles") and all amendments thereto are attached hereto, together with a current Certificate of Good Standing. The Articles have not been further amended and no proceedings have been taken or are pending to amend, surrender or cancel the same.
2. The following persons are the directors and/or officers of the Company who hold the office set out opposite their name:

<u>Name</u>	<u>Position</u>
_____	_____
_____	_____
_____	_____

3. The following persons are the shareholders of the Company who hold the shares set out opposite their respective names:

<u>Name</u>	<u>Number and type of shares held</u>
_____	_____
_____	_____
_____	_____

4. No action has been taken by either the shareholders or directors of the Company to limit or restrict the powers of the directors, including the power to enter into contracts, borrow money and give security therefor, as conferred under the Act. There are no provisions in the Articles or by-laws of the Company or any unanimous shareholder agreement or declaration with respect to the Company which restricts, limits or regulates the powers of the Company or the directors of the Company to borrow money upon the credit of the Company, to issue, re-issue, sell or pledge debt obligations of the Company, to give guarantees on behalf of the Company, or to hypothecate, pledge, transfer, assign or subject to a security interest any of the present and future property, real and personal, movable and immovable, undertaking, rights and assets of the Company.
5. No proceedings are pending for the forfeiture of the Company's Certificate of Incorporation or for its dissolution, voluntarily or involuntarily.
6. The Company is duly registered, licenced and qualified and is up-to-date in the filing of all corporate and civil returns under the laws of Newfoundland and Labrador and any other jurisdiction where the nature of its business or the assets owned or leased by it so requires.
7. I have reviewed the terms of the Documents. Any director or officer who executes the Documents on behalf of the Company has full authority to so execute on behalf of the Company and to bind the Company with respect thereto.
8. The Company is not presently a party to any material litigation or proceedings and there is no litigation or proceedings pending or threatened against the Company before any court, administrative board or agency, or any other tribunal and we know of no facts which might give rise to any such litigation or proceedings.
9. The Company has fully and adequately insured all of its property and assets to the full insurable value thereof with a reputable and established insurer.

10. There is no outstanding liability to any government or governmental or statutory agency or authority whereby any lien is outstanding or pending.
11. The Company has full capacity and power to own its properties, to carry on its business as the same is presently conducted, and execute and deliver the Documents.
12. The entry into, execution and delivery of, and the performance of the obligations under and pursuant to the Documents by the Company do not conflict with or result in the breach of or constitute a default under any bond, debenture, notice, mortgage, indenture, agreement or other instrument to which it is a party.

Dated this ____ day of _____, 20__.

President & Secretary



Appendix A - BUSINESS REFERENCE

Date: _____

To: _____

Attn: _____

Phone: _____

Fax Number: _____

From: _____

Attn: _____

Phone: _____

Fax Number: _____

As part of the review of the above applicant for a Liquor Express store, the Newfoundland Labrador Liquor Corporation requires the credit and business status of the applicant with your company. Please complete and return this document regarding the above referenced applicant at your earliest opportunity.

- 1) Amount of Credit granted: _____
- 2) Annual business volume: _____
- 3) Term Credit (Payment): _____
- 4) Credit Rating: _____
- 5) Present Account Balance: _____
- 6) Status of Account (s): _____

Additional Comments:

Company Official Signature



Wine Fixture shelving requirements;

48" LONG SECTION

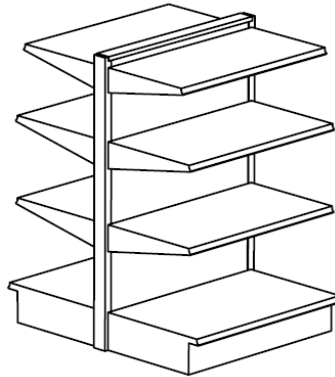
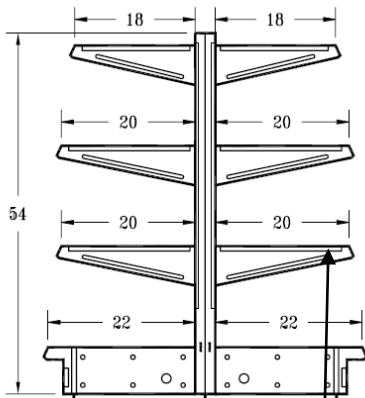

GENERAL SPECIFICATION
POST :
12 GAUGE - HSLA
BASE FOOT :
14 GAUGE - HSLA
FRONT KICK PLATE:
22 GAUGE
BASE SHELF AND REGULAR
PERFORATED SHELF:
22 GA
SHELF BRACKET:
12 GAUGE - HSLA
TOP CAP:
22 GA

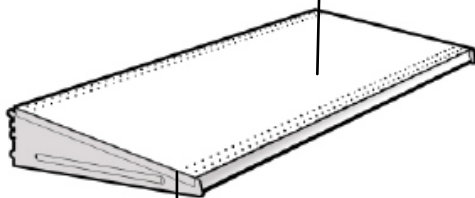

- **Standard one-piece shelf** with a 1 ¼ " steel ticket moulding on the front edge.

- Shelf made of 12 gauge steel, baked enamel finish and perforated.

Perimeter (Spirits) shelving requirements;

36" LONG SECTION

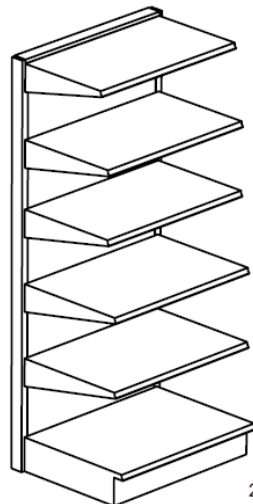
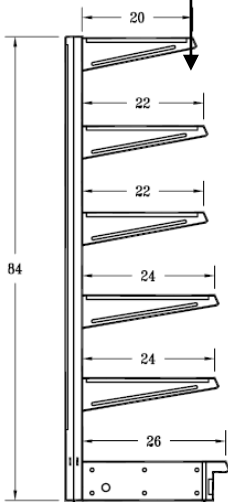

GENERAL SPECIFICATION
POST :
12 GAUGE - HSLA
BASE FOOT :
14 GAUGE - HSLA
FRONT KICK PLATE:
22 GAUGE
BASE SHELF AND REGULAR
PERFORATED SHELF:
22 GA
SHELF BRACKET:
12 GAUGE - HSLA
TOP CAP:
22 GA